



TORNADO

LED BEACON



- Magnetic & suction mount available
- Available in blue, amber, red, green or white LED
- Ultra bright latest generation OSRAM LED's
- Wide angle FX optics, 360 degree visibility
- 9 flash patterns including rotate
- UV stabilised polycarbonate lens
- 20w Neodymium speaker
- Inbuilt 20w digital siren
- 11 – 30 volt operation
- 115dB output (single unit)
- IP54 Dust & Water resistant
- EMC/R10 compliant
- ECE R65 approved Class II Amber, Class II Blue
- DEKRA speed approved (236.2kph / 146.6mph)
- Dimensions: 172.mm x 180mm x 1.54mm
- Light weight design
- Multi-function cig plug included
- Safety lanyards Included
- Carry bag included (mag only)
- 2 Year Warranty
- Manufactured in the United Kingdom





Tornado X V2.0 Beacon Datasheet

Description

The Tornado-X is a combination emergency light/siren and 20w neodymium speaker system. The extremely lightweight assembly is ideal for users who don't necessarily want a permanent mounted solution on their vehicle. It also eliminates any installation costs. Redtronic manufactures the Tornado-X in single or dual colour with a number of worldwide tones available. The magnetic version has been DEKRA speed tested to 236kmh/146mph.

Part Numbers

| PART NUMBER | LED COLOUR | LENS COLOUR | SIREN TONES | FIXING METHOD |
|--------------|------------|-------------|---------------|---------------|
| TR12XB0BIN4M | BLUE | BLUE | INTERNATIONAL | MAGNETIC |
| TR12XB0CIN4M | BLUE | CLEAR | INTERNATIONAL | MAGNETIC |
| TR12XB0BIN4S | BLUE | BLUE | INTERNATIONAL | SUCTION |
| TR12XB0CIN4S | BLUE | CLEAR | INTERNATIONAL | SUCTION |
| TR12XA0AIN4M | AMBER | AMBER | INTERNATIONAL | MAGNETIC |
| TR12XA0CIN4M | AMBER | CLEAR | INTERNATIONAL | MAGNETIC |
| TR12XA0AIN4S | AMBER | AMBER | INTERNATIONAL | SUCTION |
| TR12XA0CIN4S | AMBER | CLEAR | INTERNATIONAL | SUCTION |
| TR12XG0CIN4M | GREEN | CLEAR | INTERNATIONAL | MAGNETIC |
| TR12XG0CIN4S | GREEN | CLEAR | INTERNATIONAL | SUCTION |
| TR12XR0CIN4M | RED | CLEAR | INTERNATIONAL | MAGNETIC |
| TR12XR0CIN4S | RED | CLEAR | INTERNATIONAL | SUCTION |
| TR12XB0BDE1M | BLUE | BLUE | GERMAN | MAGNETIC |
| TR12XB0CDE1M | BLUE | CLEAR | GERMAN | MAGNETIC |
| TR12XB0BDE1S | BLUE | BLUE | GERMAN | SUCTION |
| TR12XB0CDE1S | BLUE | CLEAR | GERMAN | SUCTION |
| TR12XA0ADE1M | AMBER | AMBER | GERMAN | MAGNETIC |
| TR12XA0CDE1M | AMBER | CLEAR | GERMAN | MAGNETIC |
| TR12XA0ADE1S | AMBER | AMBER | GERMAN | SUCTION |
| TR12XA0CDE1S | AMBER | CLEAR | GERMAN | SUCTION |
| TR12XG0CDE1M | GREEN | CLEAR | GERMAN | MAGNETIC |
| TR12XG0CDE1S | GREEN | CLEAR | GERMAN | SUCTION |
| TR12XR0CDE1M | RED | CLEAR | GERMAN | MAGNETIC |
| TR12XR0CDE1S | RED | CLEAR | GERMAN | SUCTION |

Not found what you're looking for? Redtronic manufactures this product in blue, amber, red, green, white and many other colours in single and dual colour. Contact us to identify which part number you will require.





Tornado X V2.0 Beacon Datasheet

Technical Information

| | |
|-------------------------------|------------------------------------------------------------------------------------------------|
| Voltage Range (DC) | 11 – 30v |
| Number of LEDs | 12 |
| LED Brand | OSRAM |
| Led Power (Watts) | 36 |
| Light Output (Lumens) | Amber: 2745 Blue: 1905 Red: 2595 White: 4380 Green: 2910 |
| Weight (Grams) | Magnetic: 2350G Suction: 2260G |
| 'All on' - Current Draw (12v) | 4.1 Amps |
| IP rating | IP54 (Tornado X assembly) IP66 (beacon) IP67 (speaker/siren) |
| Output dB | 115dB |
| Approval | ECER65 Class II DEKRA SPEED TEST (magnetic mount) 236.2KPH/146.6MPH EMC/R10 compliant |
| Warranty | 2 Years |

Dimensions

| Fixing Method | Height | Width | Length |
|---------------|---------|-------|--------|
| Mag Mount | 172.9mm | 180mm | 154mm |
| Suction Mount | 220mm | 180mm | 154mm |

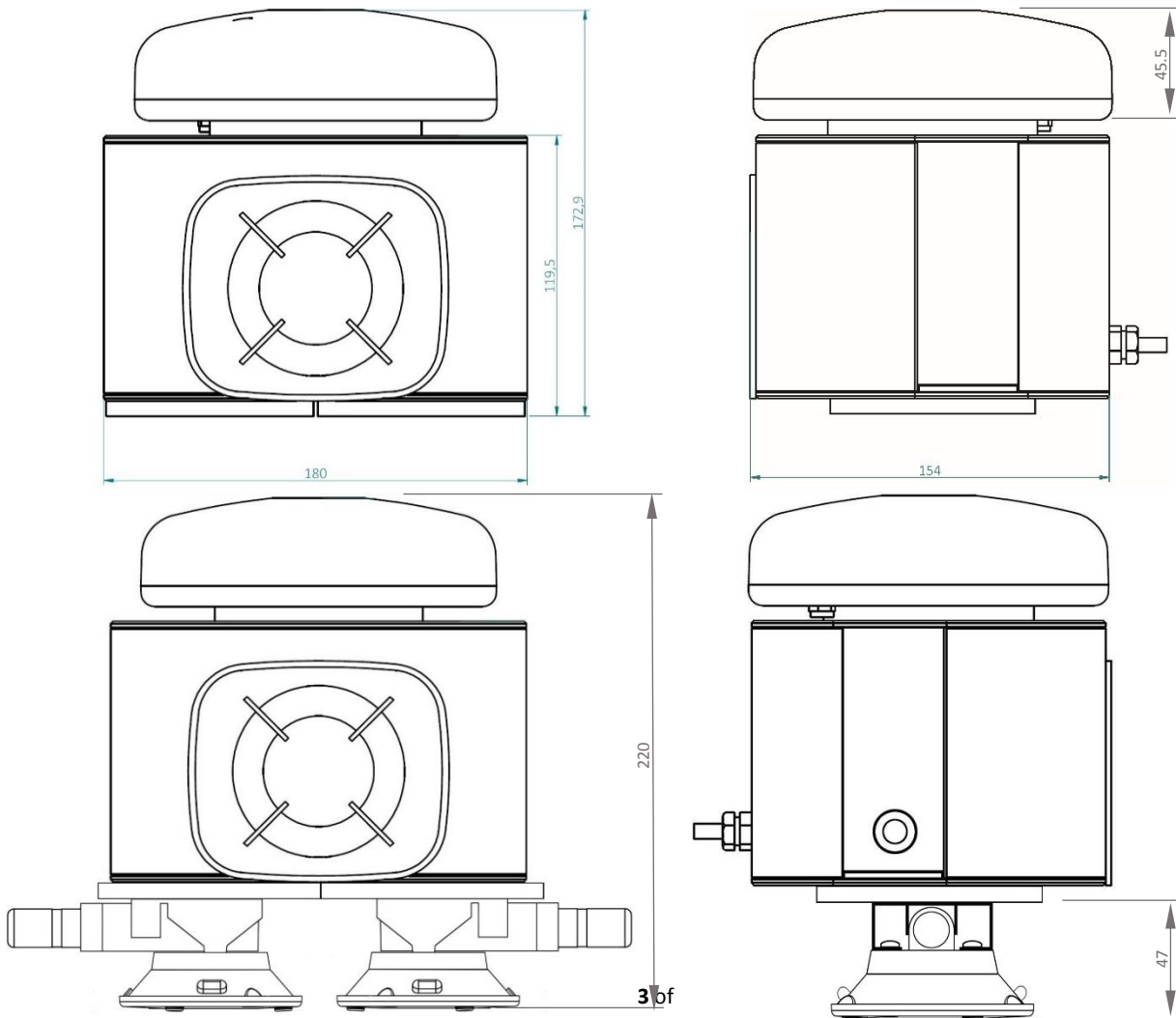



Installation – Magnetic & Suction Cup Mounts

Before attaching your Tornado X unit to a vehicle, ensure the vehicle surface is clean and free of any dirt, dust, water or grease, as this could impair the magnetic/suction performance of the Tornado X

Suction cup: Pump the plunger until the cup attaches completely. When the red line on the plunger is hidden, the cup is ready for use.

Check the plunger frequently to make sure the cup remains securely attached. If the red line appears, pump the plunger until the red line is hidden again.

Depending upon specification, the Tornado X will be supplied with either of the following cigarette plugs. The latching-momentary cig plug is standard for Tornado X UK/International configuration. Non-switchable cigarette plug is used in conjunction with the R400 switch panel for the German Tornado X.

UK/INTERNATIONAL

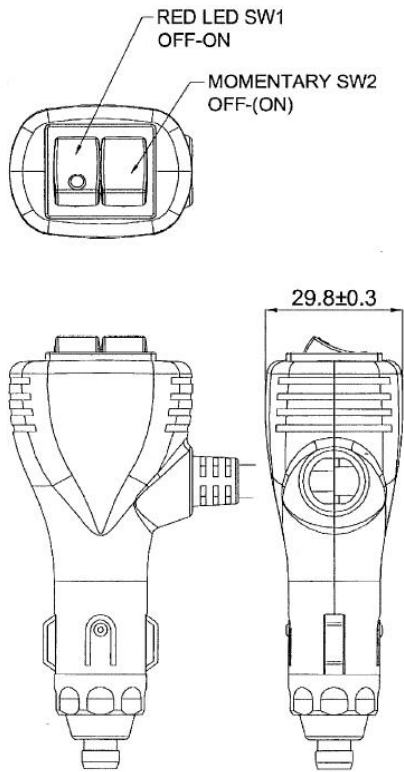

LATCHING RED LED SW1: Beacon on/off
MOMENTARY SW2: Tone select wail/yelp (double-tap for off)

GERMAN

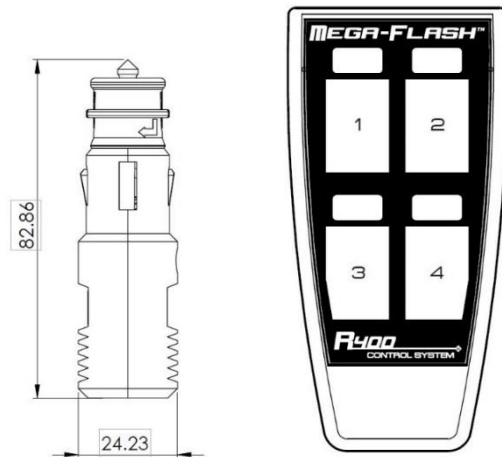

LATCHING SW1: Beacon on/off
LATCHING SW2: Country tone on/off
LATCHING SW3: City tone on/off
LATCHING SW4: Kompressor tone on/off





Installation – Lanyard Attachment



Redtronic recommends using the supplied x2 1m safety lanyards with the Tornado X for extra security

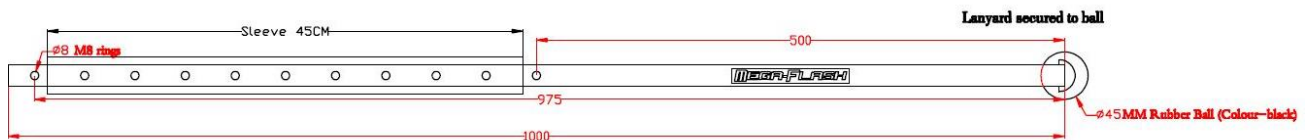

Remove the supplied spring clips fitted on the sides Tornado X enclosure and attach the safety lanyards



Place the ball end of the lanyard through the vehicle door or window and **ensure the door or window is closed securely**. In the event of the Tornado X detaching from the roof while the vehicle is in motion, the ball lanyards will trap and prevent hazard and/or loss of the Tornado X





Flash Patterns

| | |
|---------------------------|---|
| Mega-Flash (simultaneous) | ✓ |
| Quad (simultaneous) | ✓ |
| Triple (simultaneous) | ✓ |
| Double (simultaneous) | ✓ |
| Single (simultaneous) | ✓ |
| Hyper (simultaneous) | ✓ |
| CAP168/Airport (60pm) | ✓ |
| Rotate Slow (61pm) | ✓ |
| Rotate Fast (122pm) | ✓ |

To select flash pattern:

Press the pattern select button located on the left side of the Tornado X enclosure to change through the 9 flash patterns. Hold the pattern select button down for 3 seconds to return to the Mega-Flash pattern.

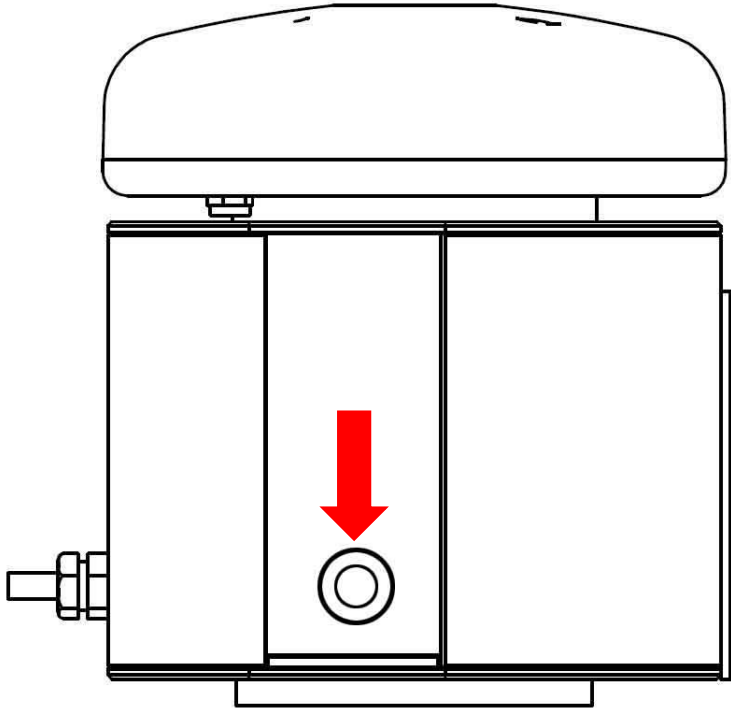

Associated Datasheets

- Suction cup maintenance
- ECE R65 Class II approval
- DEKRA speed approval

